

Tubular Handles

Tube Aluminum, Legs Zinc Die Casting

SPECIFICATION

Types

- Type **A**: Mounting from the back (threaded blind bore)
- Type **B**: Mounting from the operator's side (only for $d_1=28$)

Handle tube

Aluminum, wall thickness 1.5 mm

- Powder coated
Black RAL 9005, textured finish **SW**
Handle legs black
- Anodized, natural color **EL**
Handle legs black
- Anodized, natural color **ES**
Handle legs silver

Handle legs

Zinc die casting

Powder coated, textured finish

- Black, RAL 9005 for SW / EL
- Silver, RAL 9006 for ES

Cover

Plastic, light gray

Cover cap for type B

Plastic

- Black for SW / EL
- Light gray for ES

INFORMATION

The handle tube of the GN 333 tubular handles can be screwed to the handle bases without further machining or processing, allowing **special lengths** to be realised easily.

A typical application area for tubular handles GN 333 are double-winged doors at machines or devices.

Further handle legs can be added for very long tubular handles. Individual handle legs for tubular handles $\varnothing 28$ (type A) are available under GN 333.8 (see page 501).



ACCESSORY

- GN 333.8 Handle Legs (for Tubes $\varnothing 28$) (see page 501)

TECHNICAL INFORMATION

- Load Rating Information (see page A35)

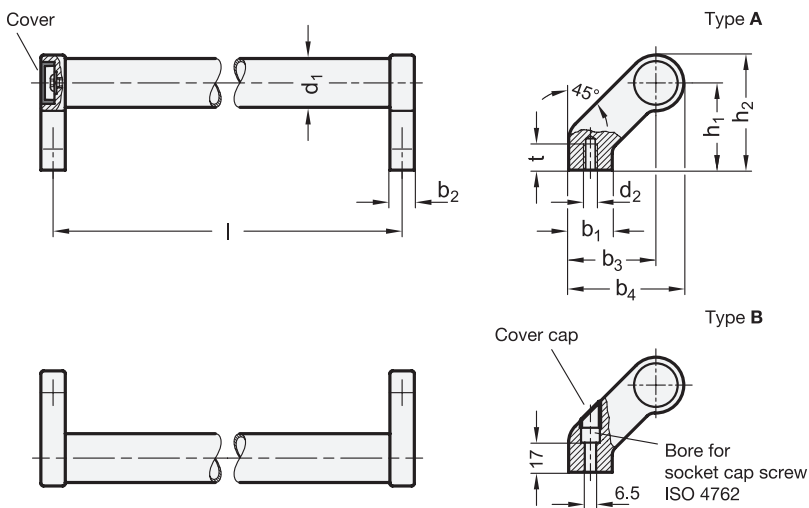

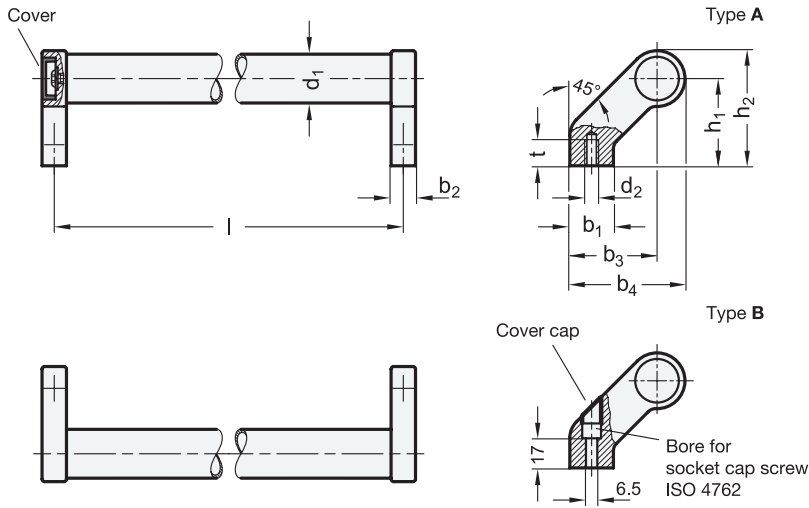

* Complete with

SW EL ES
 RAL9005 Anodized, natural color Anodized, natural color

GN 333-A

Description	d1	l ±0.25	d2	b1	b2	b3	b4	h1	h2	t min.	⚖️
GN 333-20-180-A-*	20	180	M 6	24	12	42	54	42	54	12	242
GN 333-20-200-A-*	20	200	M 6	24	12	42	54	42	54	12	246
GN 333-20-250-A-*	20	250	M 6	24	12	42	54	42	54	12	265
GN 333-20-300-A-*	20	300	M 6	24	12	42	54	42	54	12	283
GN 333-20-350-A-*	20	350	M 6	24	12	42	54	42	54	12	302
GN 333-20-400-A-*	20	400	M 6	24	12	42	54	42	54	12	321
GN 333-28-200-A-*	28	200	M 8	25	14	50	66	50	66	15	421
GN 333-28-250-A-*	28	250	M 8	25	14	50	66	50	66	15	455
GN 333-28-300-A-*	28	300	M 8	25	14	50	66	50	66	15	470
GN 333-28-350-A-*	28	350	M 8	25	14	50	66	50	66	15	495
GN 333-28-400-A-*	28	400	M 8	25	14	50	66	50	66	15	500
GN 333-28-500-A-*	28	500	M 8	25	14	50	66	50	66	15	520
GN 333-28-600-A-*	28	600	M 8	25	14	50	66	50	66	15	580
GN 333-30-200-A-*	30	200	M 8	27	17	51	68	51	68	15	600
GN 333-30-300-A-*	30	300	M 8	27	17	51	68	51	68	15	620
GN 333-30-350-A-*	30	350	M 8	27	17	51	68	51	68	15	670
GN 333-30-400-A-*	30	400	M 8	27	17	51	68	51	68	15	680
GN 333-30-500-A-*	30	500	M 8	27	17	51	68	51	68	15	700
GN 333-30-600-A-*	30	600	M 8	27	17	51	68	51	68	15	720
GN 333-30-1000-A-*	30	1000	M 8	27	17	51	68	51	68	15	800

GN 333-B

Description	d1	l ±0.25	b1	b2	b3	b4	h1	h2	⚖️
GN 333-28-200-B-*	28	200	25	14	50	66	50	66	420
GN 333-28-250-B-*	28	250	25	14	50	66	50	66	440
GN 333-28-300-B-*	28	300	25	14	50	66	50	66	458
GN 333-28-350-B-*	28	350	25	14	50	66	50	66	483
GN 333-28-400-B-*	28	400	25	14	50	66	50	66	506
GN 333-28-500-B-*	28	500	25	14	50	66	50	66	556
GN 333-28-600-B-*	28	600	25	14	50	66	50	66	600

Weight SW

